



**IMPORTANT:** Please take the time to read through the ENTIRE instructions prior to starting any work. Not following the instructions will invalidate the warranty.

## PRECAUTIONS:

1. The solar attic fan is fully functional out of the box. THE FAN WILL OPERATE AS SOON AS THE SOLAR PANEL IS EXPOSED TO THE SUN. PLEASE USE CAUTION AND AVOID THE FAN BLADES DURING INSTALLATION.
2. Ensure normal safety precautions are taken when using tools, ladder and walking on roofs.
3. Do not cut any structural members in the house.
4. Install only in dry weather.

## TOOLS/MATERIALS NEEDED

- |                       |                     |
|-----------------------|---------------------|
| ■ Caulk               | ■ Reciprocating Saw |
| ■ Caulking Gun        | ■ Safety Goggles    |
| ■ Ladder              | ■ Soft Cloth/Towel  |
| ■ Marking Pencil      | ■ Stud Finder       |
| ■ Measuring Tape      | ■ String            |
| ■ Philips Screwdriver | ■ Utility Knife     |

### IMPORTANT Choose Where to Install Unit:

When determining location of the unit, try to place the solar attic fan on the south side of the roof, also consider potential problems such as objects shading the unit during certain times of the day. If possible, the unit should be installed between rafters (see Step 3). If the roof has no ridge vent, the center of the unit should be about 2 feet down from the roof ridge. If there's a ridge vent, the center of the unit should be about 5 feet down from the roof ridge.

## SOLAR ATTIC FAN KIT PARTS:

**Note:** Exploded view is for illustrative purposes. Unit comes pre-assembled.

- A. Adjustable PERC Solar Panel (16, 32 or 48 watt)
- B. (2) Self-Tapping Bracket Screws
- C. (2) Solar Panel Aluminum Brackets
- D. Aluminum Housing
- E. Wire Lead
- F. Custom DC Motor with Isolation Bracket
- G. Precision Pitch 5 Blade Fan
- H. 3.25" x 48" Stainless Steel Wire Mesh
- I. (4) Aluminum "L" Brackets
- J. Storm Collar
- K. (6) #10 x 1.5" Stainless Steel Philips Head Screws
- L. Aluminum Flashing

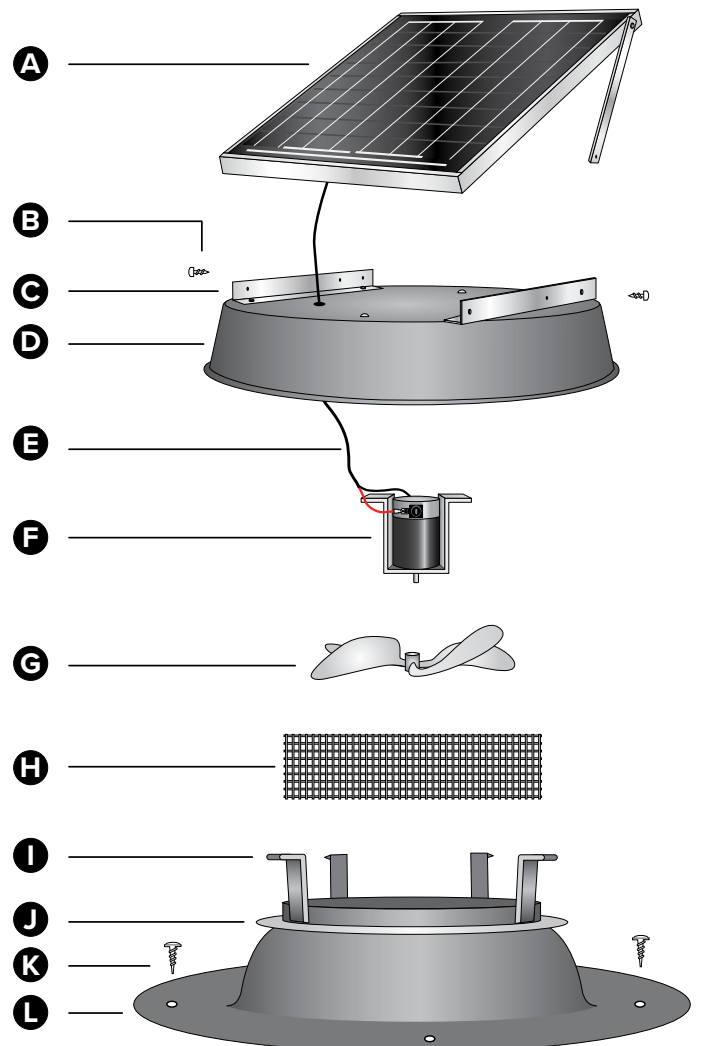

**STEP 1**

Choose location for the solar attic fan, southern exposure is best. If a southern exposure is not feasible for your installation, the fan can be installed on any other exposure and the solar panel adjusted to capture maximum sunlight.



**STEP 2**

**DETERMINE SIZE OF HOLE NEEDED FOR YOUR INSTALLATION:**

On 24" on center construction, center the fan between the rafters and cut a 19" hole. On 16" on center construction, the installer can either cut a 14" hole between the rafters or cut a 19" hole with the roof rafter running through the hole (see illustration below in Step 4).

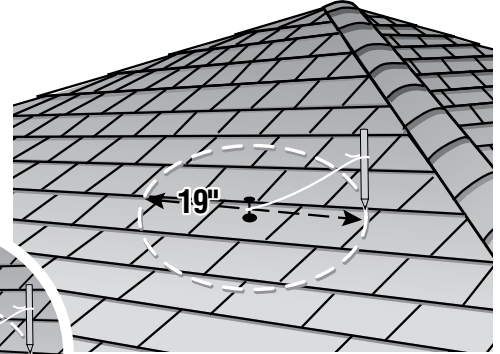

**STEP 3**

Hammer a nail at the center of the location chosen for the solar attic fan between rafters. The center of the unit should be about 2 feet down from the ridge.

**19" HOLE:** Attach a string to the nail. Measure 9.5" of string and attach a marking pen to the string, see diagram. Scribe a 19" circle onto the roof shingles.

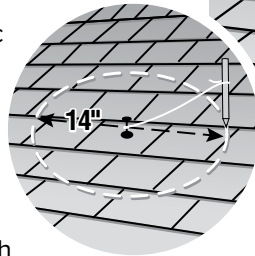

**14" HOLE:** Attach a string to the nail. Measure 7" of string and attach a marking pen to the string, see inset. Scribe a 14" circle onto the roof shingles.

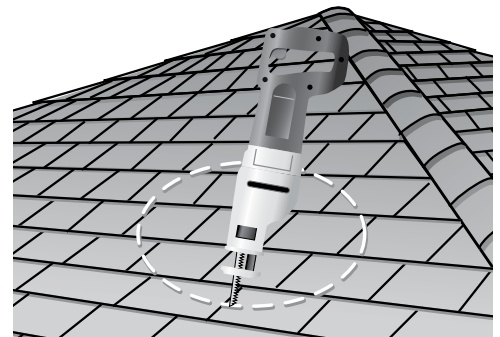

**STEP 4**

With a reciprocating saw, cut the diameter of the hole. **NEVER CUT THROUGH ANY ROOF RAFTERS. LEAVE ALL FRAMING MEMBERS IN PLACE.**

**IMPORTANT:** The solar attic fan must be installed between the roof rafters OR over a roof rafter. **DO NOT CUT THROUGH ANY FRAMING MEMBER.** Only remove roof sheathing.

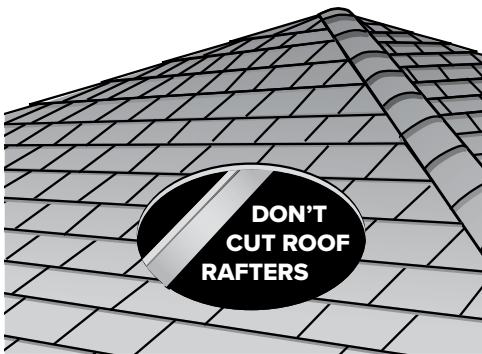

**RECOMMENDED:**  
HOLE CUT  
BETWEEN RAFTERS

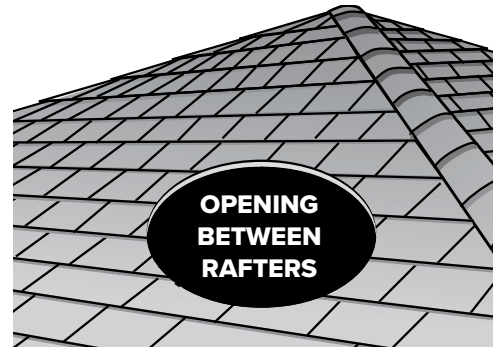

**OPTION:**  
16" ON CENTER  
WITH 19" HOLE

**STEP 5**

**19" HOLE:** With a razor knife, cut a four inch slit through the shingles and tar paper at the three and nine o'clock positions of the flashing. This allows for the foot print of the flashing to be inserted under the shingles.

**14" HOLE:** Additional shingles may also need to be removed on the high side towards the ridge to allow the flashing to slide over the hole (see inset).

**19" HOLE**

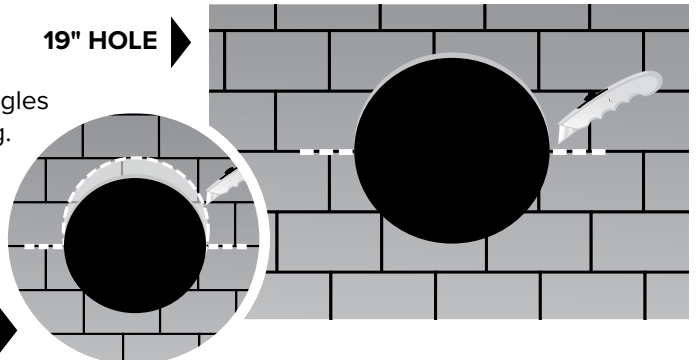

**14" HOLE**

### STEP 6

Insert the reciprocating saw blade sideways at the three o'clock position and commence cutting the roofing nails up and around to the nine o'clock position. This process removes the nails that will prevent the flashing footprint from sliding up underneath the shingles.

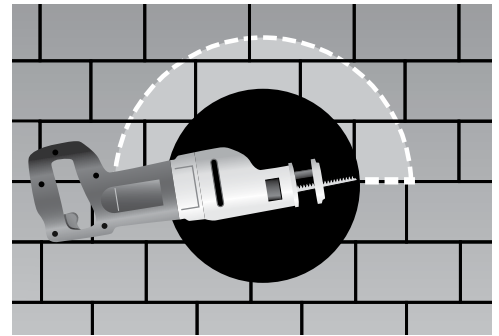

### STEP 7

Carefully turn the solar attic fan unit upside down and place it on a soft cloth or towel to prevent damaging the solar panel. Caulk the **underside** of the flashing. Two concentric rings of caulking material is sufficient.

**NOTE:** Installation on tile roofs will require the use of a tile skirt.

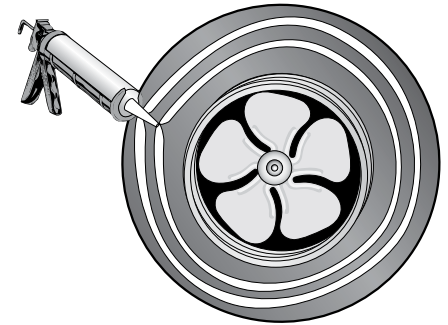

### STEP 8

Taking care not to smear caulk on the exposed shingles, slide flashing under tar paper and shingles and force flashing up until the shingles come in contact with the raised portion of the flashing. The bottom side of the flashing will be on top of the shingles. Secure flashing with provided (6) Phillips head screws through the pre-drilled holes on the flashing footprint.

**NOTE:** Local Building Code requirements may specify anchoring that requires additional screws installed in the flashing.

**Florida Dept. of Community Affairs:**

[http://www.floridabuilding.org/pr/pr\\_app\\_srch.aspx](http://www.floridabuilding.org/pr/pr_app_srch.aspx)

**Texas Dept. of Insurance:**

<http://www.tdi.state.tx.us/wind/prod/indexrv.html>

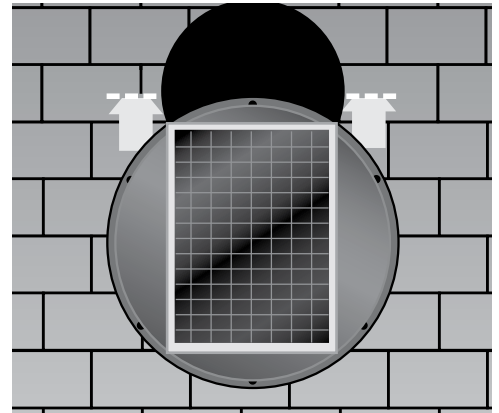

### STEP 9

Caulk over the screw heads that are exposed to the weather. Use remaining caulk to seal the areas where the 4" slits were made in Step 5 and around the area where the shingles meet with the raised area of the flashing.

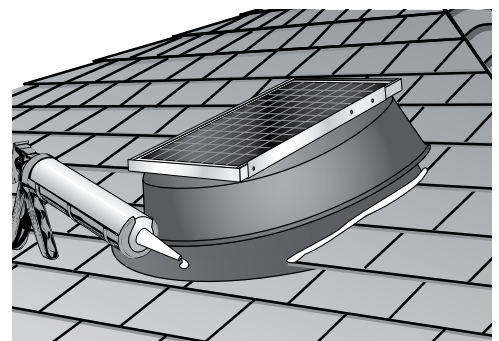

### STEP 10

Adjust the solar panel to the position it will collect the most sunlight throughout the day. (The panel can be left in the down position.) To adjust the solar panel, remove the (2) self-tapping screws on either side of the bracket. Lift up the solar panel and line up the pre-drilled hole on the bracket arm to one of the two pre-drilled holes on the "L" bracket attached to the housing. Re-attach the (2) self-tapping screws on both sides.

**IMPORTANT:** Prior to an anticipated hurricane or high wind event, the solar panel must be secured with screws in the flat position.

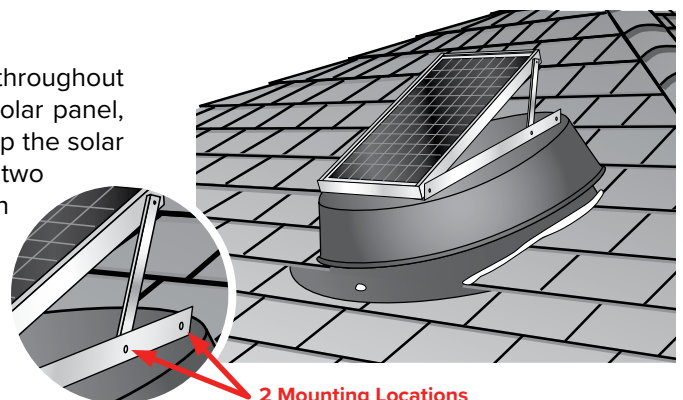

**2 Mounting Locations**



## Solar Attic Fan Limited Lifetime Warranty

Natural Light Energy System (hereinafter NLES) warrants any solar attic fan manufactured by NLES to be free from defects in materials and workmanship to the original residential purchaser (hereinafter CONSUMER) from the date of purchase. All aspects of the Warranty are subject to the following limitations, terms and conditions.

### 1. DURATION OF WARRANTY

If a NLES solar attic fan (hereinafter "Equipment") is determined to have a defect in material or workmanship, NLES will, at its sole discretion, repair or replace the defective part at NO CHARGE to the CONSUMER, (excluding labor, and applicable shipping and handling costs) for the duration of the CONSUMER'S ownership of the original equipment (hereinafter "LIFETIME").

### 2. LIMITATIONS OF COVERAGE

This Warranty extends only to the CONSUMER for damage resulting from defects in materials and workmanship, it does not extend to damage caused by the CONSUMER'S neglect or abuse, or by accident, to damage caused by wind, hail or abnormal weather conditions, or to damage caused by acts of God, civil insurrection or extraordinary circumstances which are beyond the control of NLES.

NLES shall not be liable for any direct or indirect damage resulting from the use of the Equipment, and in no event shall the extent of the Warranty coverage exceed the purchase price of the Equipment.

NLES assumes no liability for the determination of the proper equipment necessary to meet a CONSUMER'S requirements, nor does it authorize others to assume such obligations on its behalf.

### MISCELLANEOUS

In order to be considered for validation, all claims for Warranty coverage must be accompanied by a copy of the purchase agreement indicating the date of initial installation, NLES reserves the right to inspect the solar attic fan prior to honoring any Warranty claim.

This Warranty gives you specific legal rights, and you may have other rights which may vary from state to state. Any and all inquiries or claims under this Warranty must be submitted in writing to **Natural Light Energy Systems, Attn: Warranty Department, 10821 N. 23rd Avenue, Phoenix, AZ 85029** or by e-mail to [info@nltubular.com](mailto:info@nltubular.com).



To register your Solar Attic Fan, please visit  
[www.solaratticfan.com/customer-service/warranty-registration/](http://www.solaratticfan.com/customer-service/warranty-registration/)



**REGISTER NOW**